



Design of Integrated System for the Comprehensive Utilization of Yellow River Sediment-Sealing Machine Structure and Control System Design

Zhang Hao ^{a*}

^a School of Mechanical Engineering, North China University of Water Resources and Electric Power, Zhengzhou, China.

Author's contribution

The sole author designed, analyzed, interpreted and prepared the manuscript.

Article Information

DOI: <https://doi.org/10.9734/jerr/2024/v26i91273>

Open Peer Review History:

This journal follows the Advanced Open Peer Review policy. Identity of the Reviewers, Editor(s) and additional Reviewers, peer review comments, different versions of the manuscript, comments of the editors, etc are available here: <https://www.sdiarticle5.com/review-history/123136>

Original Research Article

Received: 03/07/2024

Accepted: 05/09/2024

Published: 09/09/2024

ABSTRACT

With the development of national industrialization, the control of yellow-river sediment needs to develop a complete automatic treatment system. In this paper, the structure and control system of the sealing machine in the integrated system design of the yellow river sediment comprehensive utilization are designed. Firstly, the overall design scheme of the sealing machine is determined, then, the structure and working principle of the sealing machine are introduced in detail. The design part of the actuator is defined. Secondly, finite element analysis is carried out for some of the stressed parts. The results show that the sealing machine system runs normally, the structure is not deformed and damaged, and it can work continuously for 12~16 hours, and the woven bag with sand can be successfully sealed. The sealing machine can not only save manpower and material

*Corresponding author: Email: 1327186777@qq.com;

Cite as: Hao, Zhang. 2024. "Design of Integrated System for the Comprehensive Utilization of Yellow River Sediment-Sealing Machine Structure and Control System Design". *Journal of Engineering Research and Reports* 26 (9):206-13. <https://doi.org/10.9734/jerr/2024/v26i91273>.

resources, but also has the characteristics of simple operation and high efficiency. However, affected by the size of the equipment, it can only work in the factory or a large flat site.

Keywords: Yellow river sediment; sealing machine; executing organs; finite element analysis.

1. INTRODUCTION

The Yellow River, the second longest river in China after the Yangtze River and the sixth longest river in the world, originates from the Qinghai-Tibet Plateau and flows through nine provinces and regions of China before flowing into the Bohai Sea. The Yellow River passes through the Qinghai-Tibet Plateau, the Loess Plateau, the Inner Mongolia Plateau and the North China Plain, of which about sevenths of the total area of the Yellow River basin is located in the loess Plateau basin, with deep loess soil distributed on the surface, loose soil and low vegetation coverage. The loess soil layer in the Loess Plateau has poor resistance to water impact, and it is very easy to disintegrate a large amount of sediment into the Yellow River along with tributaries. Even though there is little precipitation, the Yellow River has the highest sediment content in the world due to the concentration of precipitation. The Yellow River sediment content is relatively large, easy to cause the blockage of the river, and the Yellow River is still an overland river, a lot of sediment accumulated every year, resulting in higher and higher riverbed, since ancient times, the Yellow River has destroyed a large number of good fields and houses, bringing many disasters to people on both sides of the river [1]. For the control and scientific and rational use of the Yellow River sediment, it is necessary to develop a comprehensive control system, which can not only better control the Yellow River sediment, but also more efficient and efficient and save manpower [2].

After entering the 21st century, the society has rapidly entered a period of modern development, and its mechanization, intelligence and unmanned degree have been greatly deepened. In 2017, Zhao Jicheng [3] and others proposed a fully automatic plastic packaging sealing machine control and operation integrated system and designed and developed a plastic packaging sealing machine. In 2019, Zhu Xiaozhen [4] studied and designed a mushroom cultivation bag sealing machine, achieving "ring-sealing", and innovatively designed expansion devices, opening devices, etc. to provide a new research

direction for the mechanical research of "ring-sealing" for mushrooms. In 2022, Yuan Zhilin [5] and others designed a pneumatic sealing machine for ton-packaging bags, achieving precise control of the sealing temperature, and proposed a method of quickly cooling the heating strip and sealing edge using vortex tube cooling technology. Now in our daily life, all walks of life have a lot of mechanical equipment to help us work, can achieve unmanned operation, people only need to be next to the supervision and assistance, which greatly convenient us, reduce the amount of labor, and mechanical equipment manufacturing precision is relatively high, work efficiency is higher than human, promote the development of all walks of life. Compared with the United States, Germany, Japan and other countries with the highest degree of mechanization, the development of China's machinery industry started late, the degree of mechanization and automation is low, and the development prospects are great. At present, most of the domestic sealing machine equipment is used in medical, food and grain industries. The sealing machine designed in this paper is mainly used for sealing plastic woven bags filled with Yellow River sediment, which is convenient for the management and treatment of Yellow River sediment, saving manpower and speeding up efficiency.

2. SEALING MACHINE SCHEME DESIGN AND OVERALL LAYOUT

In this design, the sealing machine part of the Yellow River sediment comprehensive utilization integrated system mainly realizes automatic conveying and sealing work and unmanned operation. Its main pressure bag mechanism, belt conveyor and sewing machine three parts, the research and development of the sealing machine is mainly: power part, transmission part, executive part and control part [6,7]. Power part: The device has three main power sources. One is the motor that drives the conveyor belt to work; The other is the stepper motor to drive the sewing machine to work; The last one is the hydraulic rod, the power after the hydraulic push work. Transmission part: the working form of transmission device has belt transmission, gear

transmission, connecting rod transmission, hydraulic transmission and so on. Execution part: mainly the press bag mechanism, conveying mechanism and sealing mechanism. Control part: The use of common single-chip microcomputer equipment for control, so that the bag press mechanism, belt conveyor and sewing machine cooperate.

2.1 Overall Scheme

The machine is mainly composed of five parts: conveyor belt mechanism, bag press mechanism, guide rail, sealing mechanism and console. The main design part is divided into conveying mechanism, bag press mechanism, sewing mechanism and control part [8,9]. Its various components function as follows:

Conveyor belt mechanism: The mechanism is a parallel belt conveyor, the plastic braided belt loaded with sediment for parallel transport.

Bag press mechanism: equipped with two hydraulic push rods, the woven bag loaded with sediment is pressed, the width of the woven bag mouth is reduced, and it is easy to seal.

Guide rail: the middle distance between the two baffles is 10cm, to prevent the reduced woven bag from loosening and expanding before the

bag is sealed, and to ensure that the bag mouth size can be sealed.

Sealing mechanism: The mechanical structure is used to convert the rotation of the motor into the appropriate needle sewing movement, so as to complete the sealing work.

2.2 Conveying Mechanism Design

According to the use in different environments, the requirements of users and the applicable type of conveyor, the appropriate circuit design is selected, and the overall layout of each part of the conveyor is carried out [10]. It is important to design the number of driving devices and installation positions, rollers and rollers, head and tail arrangement. According to these contents, parallel single-drum line layout is adopted, as shown in Fig. 2, two parallel line layouts. This design uses a single drum drive, a total of two layouts. The device designed in this study is to transport the sediment that can be seen everywhere along the Yellow River, and the fixed material filled with woven bags has a large quality and needs to be stable when conveying, reducing shaking to prevent the woven bag from falling down and causing the inability to carry out the next step - sealing. Considering the above factors, the second layout is adopted, which is safe and reliable [11].

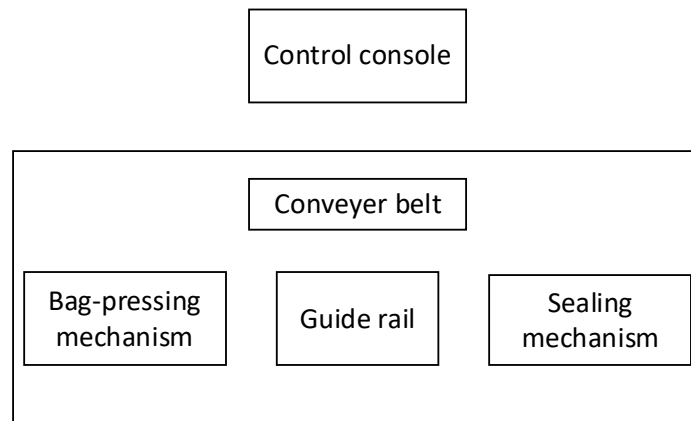

Fig. 1. Sealing machine main components diagram

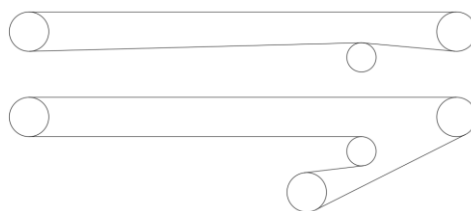

Fig. 2. Drum line layout

Rollers are parts arranged above the conveyor, whose role is to support the conveyor belt and the material transported on the conveyor belt, and can also reduce the friction of the conveyor belt operation. The use quality of the roller determines the service life of the overall mechanism, especially the impact on the conveyor belt is relatively large, so the selected roller must be durable, compact and suitable, and the operation resistance of the conveyor is small. In this design, the packaged material is transported, so the parallel upper roller is selected [12].

In the conveyor, the role of the transmission drum is to transfer the power to make the device work, first of all, the belt transmits the power of the motor to the device, and then the drum rotates and produces friction with the conveyor belt to make the conveyor belt rotate. According to the load borne during transportation, the transmission drum is divided into light, medium and heavy.

The conveyor belt can transport 4-5 bags of materials each time, each bag weighs about 84kg, and the total weight is 416kg; The selected driving drum is: diameter $D=240\text{mm}$, allowable torque $500\text{N}\cdot\text{m}$, length $L=730\text{mm}$, weight 65.5kg.

The belt conveyor is designed for short-term work, so the AC motor can be selected for short-term work, and the belt drive is adopted. Y series motor structure is simple, safe and reliable, and easy maintenance, the cost is suitable, the disadvantage is that the starting performance and speed regulation performance is poor, but the design of the conveyor on the starting performance and speed regulation performance requirements are not high, so suitable for selection. According to the transportation machinery manual, you can choose the Y100L-2 type motor, rated power is 3KW, the reducer model is BWD3-3, the line speed of the drum is 0.43, 0.52, 0.79, 1.01, 1.44, 1.66, and the full speed is 1470r/min.

2.3 Design of Sewing Machine

The main parts of the industrial sewing machine are: body part, needle rod and picking device, press foot device, feeding device, spinning shuttle device, threading device, winding device, tangential device, control box and motor device, etc [13]. The main four mechanical structures are acupuncture mechanism, swing shuttle mechanism, picking mechanism and feeding

mechanism. The structure of the sewing machine is relatively compact, and the mechanical composition is complex, but each unit is closely connected and strictly coordinated, so this paper only introduces part of the structure, of which the four major mechanisms function as follows:

Needling mechanism: the machine needle in the mechanism penetrates the sewing material and takes the surface thread through the sewing material to form a thread ring. The process of forming the wire ring can be divided into four stages, which are the needling stage, the lead stage, the wire ring stage and the needle withdrawal stage.

Swing shuttle mechanism: when the machine needle takes the thread through the sewing material to produce a thread ring, the shuttle tip on the mechanism then hooks the thread ring and covers the shuttle, and then the thread at the bottom of the shuttle passes through the surface line and the thread ring is thrown off, and then the swing shuttle begins to swing back after the surface line is pulled tight.

Thread picking mechanism: its purpose is to pull the thread required by the seam from the spool for the machine needle to use, and when the bottom line passes through the thread ring of the surface line, the surface line will be tightened by the mechanism [14].

Feeding mechanism: its role is to make the seam pressed and pushed by the tooth plate, moving a needle distance is to send a seam, and the tooth plate moving process for feeding is like a rectangular trajectory. At the same time, a needle distance adjustment mechanism is attached to a feeding mechanism, which changes the control feeding length (needle distance) by changing the side length of the approximate rectangular track.

2.4 Bag Press Mechanism Design

The design of the press bag mechanism is relatively simple, and three design requirements need to be paid attention to in the design: first, as long as the two baffles can be pushed, there is no need for too much thrust; The second is to need enough speed to save time; The third is that the selected push device has the right push and the size is suitable for installation.

According to the size of the woven bag, the width of the woven bag mouth after loading the sand is

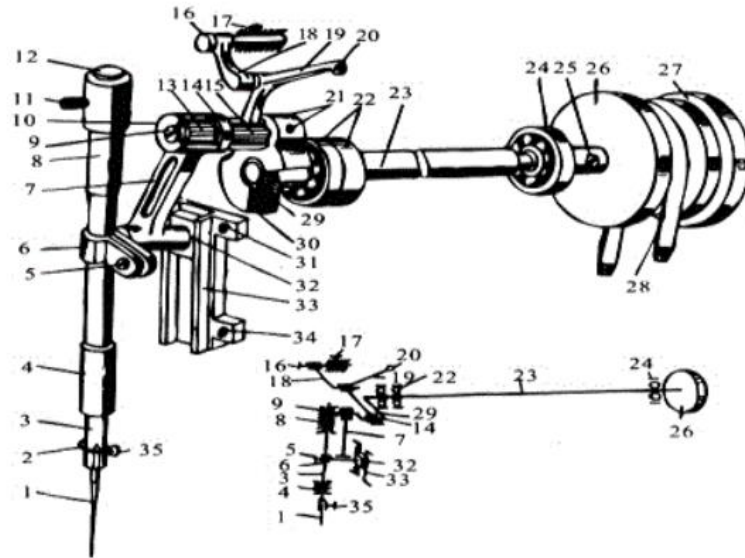

Fig. 3. Structure diagram of sewing machine



Fig. 4. Linear actuator

about 20-30cm, so the electric push rod with a push distance of 200mm can be selected. Because it does not need too much thrust, it is only necessary to push the sheet forward, the length of the sheet is 50cm, and the speed is as fast as possible. After comprehensive consideration, an electric push rod with a speed of 90mm/s and a thrust of 10kg is selected and arranged on both sides of the conveyor belt.

3. IMPLEMENTATION OF CONTROL SYSTEM

In this design, single-chip microcomputer is used to control the press bag mechanism and conveyor, and the sewing machine itself has its own control system. The design of the Arduino development board is relatively clear and simple. An AVR single chip microcomputer, a crystal oscillator or oscillator and a 5V DC power supply are generally connected to the computer with a data cable through the USB interface. There are many types of Arduino development boards, of which the most common is the Arduino UNO. And there are many micro, small, Bluetooth - and Wifi-based multiple development boards [15,16].

The mechanical structure part of the sealing machine has been basically designed, in order to achieve the sealing of the woven bag with sand, it is necessary to ensure that the various components of the sealing machine can accurately work together to prevent the failure and inconsistent cooperation resulting in the sealing machine can not normally seal the bag, so the control system of the sealing machine is the core of the normal and complete cooperation between the various institutions. When the sand loaded woven bag is placed on the conveyor belt, the ultrasonic detection module at the bottom of the bag pressing mechanism detects a change in distance, the electric push rod of the bag pressing mechanism starts to work, the speed is 90mm/s, the push distance is 200mm, three seconds later the conveyor of the conveying mechanism starts to work, the woven bag begins to move along the conveyor belt, and is transported to the location of the sewing machine. The sewing machine is equipped with a photoelectric sensor to detect the woven bag, and then automatically sew the bag and cut the thread automatically. The woven bag is transported to the end with the conveyor belt.

4. SEALER FORCE PART SIMULATION ANALYSIS

The deformation and stress changes of the conveyor belt are calculated. Fig. 6 is the overall deformation diagram of the conveyor belt, and Fig. 7 is the stress cloud diagram of the conveyor belt. It can be seen that the deformation and

strain of the conveyor belt are very small, which conforms to the design criteria.

The deformation and stress changes of the idlers are calculated. Fig.8 is the overall deformation diagram of the idlers, and Fig. 9 is the stress cloud diagram of the idlers. It can be seen that the deformation of the idlers is up to 0.016mm and the maximum stress is 8.88MPa, which conforms to the design criteria.

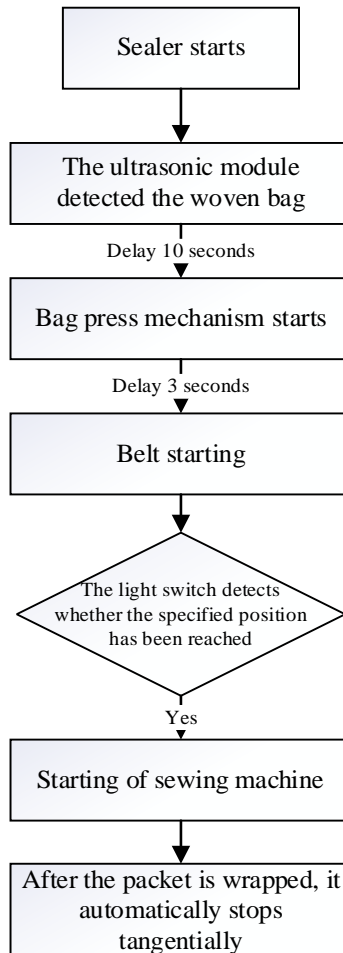

Fig. 5. Sealing machine control flow chart

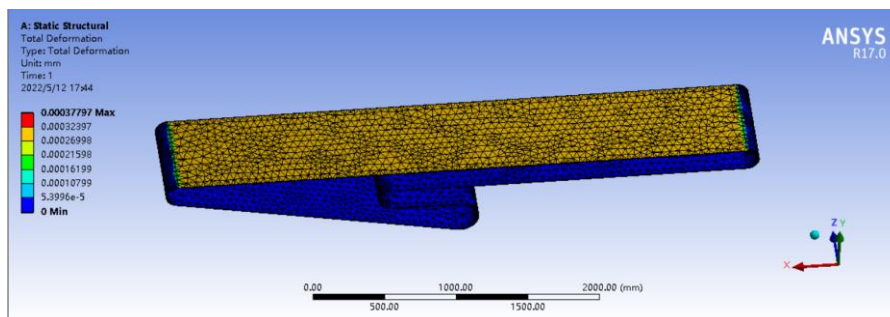

Fig. 6. Overall deformation of the conveyor belt

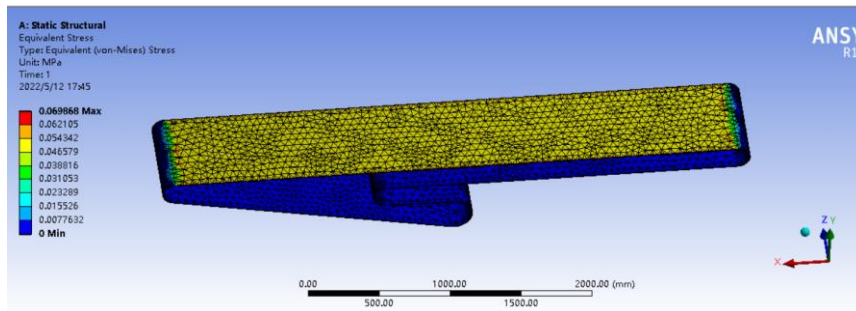

Fig. 7. Stress distribution cloud image of conveyor belt

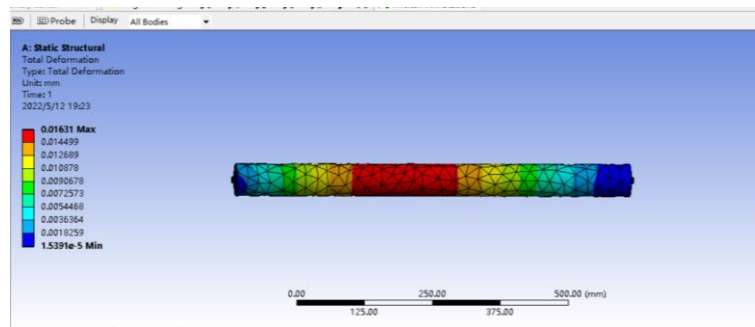

Fig. 8. Overall deformation of parallel upper idlers

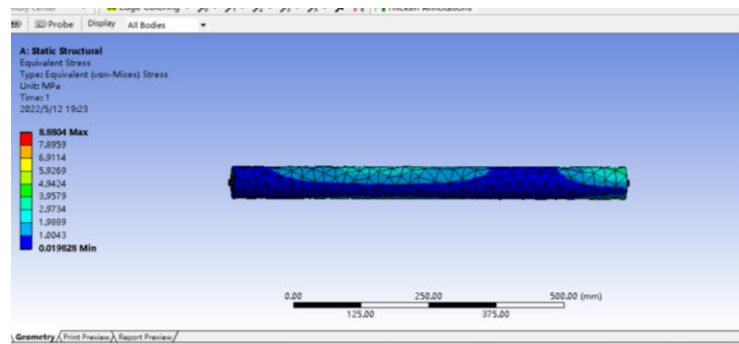

Fig. 9. Stress Distribution Cloud Image Of Parallel Upper Idlers

5. CONCLUSION

The research and application of the integrated system for the comprehensive utilization of Yellow River sediment not only improves the efficiency of the Yellow River sediment control, but also saves a lot of manpower and material resources. The automatic operation could improve the control of Yellow River sediment. In the process of running and debugging the prototype, the rationality and stability of the mechanism design are preliminarily verified, and the design expectation is reached.

DISCLAIMER (ARTIFICIAL INTELLIGENCE)

Author(s) hereby declare that NO generative AI technologies such as Large Language Models

(ChatGPT, COPILOT, etc) and text-to-image generators have been used during writing or editing of manuscripts.

COMPETING INTERESTS

Author has declared that no competing interests exist.

REFERENCES

1. Hui Zhilei, Liu Wankang. Study on the distribution characteristics and reasonable control of sediment in the Yellow River [J]. Science and technology innovation and application. 2018(12):37-39.
2. Li Kungeng. Key technologies and applications of sediment resources

- utilization in the Yellow River [J].People's Yellow River. 2021;43(03):2.
3. Zhao Jicheng, Tian Xueli. Design and development of plastic packaging sealing machine [J]. Plastic Industry. 2017;45(01): 61-63+104.
 4. Zhu Xiaozhen. Design and simulation research of oyster mushroom cultivation bag sealing machine [D]. Shanxi Agricultural University; 2019. DOI:10.27285/d.cnki.gsxnu.2019.000710
 5. Yuan Zhilin, Gao Cuizhi. Design and control system of air-operated sealing machine for ton packaging bag [J]. Chemical Automation and Instrumentation. 2022;49(03):326-329+380. DOI:10.20030/j.cnki.1000-3922.2022.0312
 6. Li Weicheng. Design of automatic sealing machine for packing line of powder granule and block material[J].Internal combustion engine and accessories. 2018(14):10-11.
 7. Zhang Zhenyu, Cheng Wushan. Design of automatic sealing machine for powder and block material packaging line [J].Light industrial machinery. 2017;35(06):62-67.
 8. Ishida Co. Ltd.; Patent Issued for Form-Fill-Seal Machine (USPTO 10,266,288) [J]. Journal of Engineering; 2019.
 9. Pan Liai, Du Qiuli. Improvement of Cup Body Conveying Part and Control System Design of Sealing Machine [J]. Journal of Changchun University. 2013;23(08):957-959.
 10. Zhao Xiang, WANG Rong, WANG Ruimin et al. Preliminary Design and Selection of Long distance belt conveyor [J]. Cement Technology. 2022(02):23-27. DOI:10.19698/j.cnki.1001-6171.20222023.
 11. Zhang Xiaoming, Xiao Gaobo, LIU Zhiguo et al. Design of flat belt conveyor[J].Technological Innovation and Application,2022,12(08):30-32. DOI:10.19981/j.CN23-1581/G3.2022.08.011.
 12. Wang Desheng, Chen Yafeng. Optimization of Conveyor belt Parameters and idler Spacing of Belt Conveyor [J]. Journal of Henan University of Technology (Natural Science Edition),2015,34(04):525-531. DOI:10.16186/j.cnki.1673-9787.2015.04.016.
 13. Zhao Yizhong, Zhang Jian. Development and Application of Industrial sewing machine based on Wireless Network Technology [J]. Electromechanical product development and innovation. 2017;30(05): 88-89+47.
 14. Qiu Weiming, PAN Jianguo, XU Xianguo. Industrial sewing machine pick line mechanism kinematics research [J]. Journal of modern textile technology, 2019, 27 (4):95-98. DOI: 10.19398/j.att.201810027.
 15. Zhang Shengyun. Research and Development of Step-by-step Automatic Sealing Machine Control System[J]. Modern Information Technology, 2022, 6(06): 50-54. DOI: 10.19850/j.cnki.2096-4706.2022.06.012.
 16. Gao Mingjian. Research and Development of Plastic woven bag sealing machine [D]. Shandong University of Technology; 2012.

Disclaimer/Publisher's Note: The statements, opinions and data contained in all publications are solely those of the individual author(s) and contributor(s) and not of the publisher and/or the editor(s). This publisher and/or the editor(s) disclaim responsibility for any injury to people or property resulting from any ideas, methods, instructions or products referred to in the content.

© Copyright (2024): Author(s). The licensee is the journal publisher. This is an Open Access article distributed under the terms of the Creative Commons Attribution License (<http://creativecommons.org/licenses/by/4.0>), which permits unrestricted use, distribution, and reproduction in any medium, provided the original work is properly cited.

Peer-review history:
The peer review history for this paper can be accessed here:
<https://www.sdiarticle5.com/review-history/123136>